

AE110A Sequential Controller Operation Manual

I . Panel and Terminal Diagram

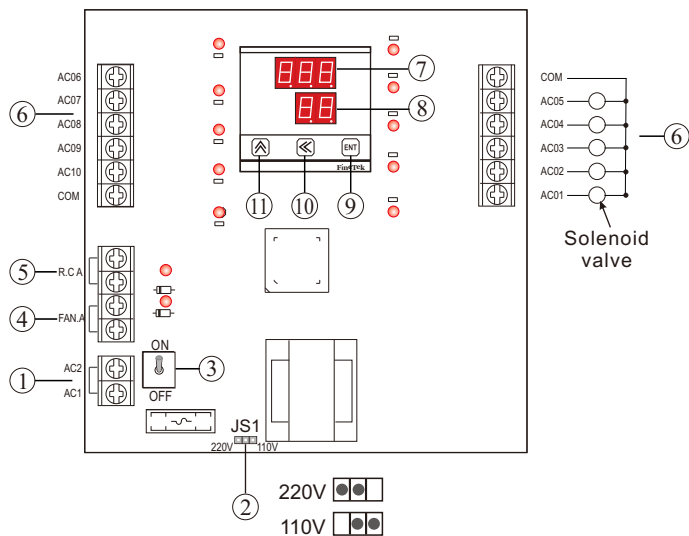

II . Terminal Description

- ① **Power supply:** (AC1, AC2)
The Controller is able to select AC110V or 220V, -10%, +20% 50/60Hz
- ② **Power supply selection:** (JS1)
Please select the power supply AC 110V or 220V.
- ③ **Power switch** (ON/ OFF)
- ④ **Fan control input:** (FAN.A)
This function is used to complete Auto-Shutdown cleaning cycle before controller stopped. When this contact is closed, controller running regularly. When this contact is open, controller will run Auto-Shutdown cleaning cycle (defined by "CLC" setting). This function is purposed to prevent dust clogged on the bag.
- ⑤ **Remote control input:** (R.C.A)
If remote control is required, please remove the short circuit, then, extend the wiring to remote site. When the remote input is open circuit, the controller will stop operation, when the remote input closed circuit, the controller resumes normal working operation.
- ⑥ **Solenoid terminals:**
Terminals are connected to solenoids.

III . Operation Panel:

- | | | |
|-----------------|------------|-----------|
| ⑦ Upper Display | ⑨ ENTER | ENT (SW1) |
| ⑧ Lower Display | ⑩ SHIFT | ◀ (SW2) |
| | ⑪ INCREASE | ▲ (SW3) |

IV .Description of Running

Upper Display	Function
999~000 S	Time to next purge
Lower Display	Function
00~nn	Next solenoid number

V .Description of Panel Setting

Upper Display	Function	Range (Time error)
Act	Purge time	001~999 S ± 5mS
int	Purge period	001~999 S ± 0.1S
CLC	Auto-Shut-Off cleaning	000~099 times
Cnt	Number of solenoid	000~nn
Lower Display	Function	Range
00~nn	Number of solenoid	01~10 ports

VI .Panel Setting Flowchart

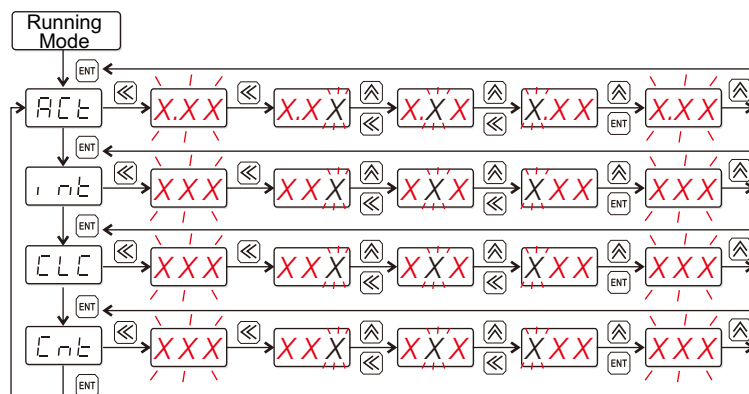

Example: To set Purge time: 1 sec.
Purge period: 10 sec.
Auto-Shutdown cleaning: 2 times
Number of solenoid: 10 ports

Follow the steps below:

- ① Press ENT into Act purge time setting.
- ② Press ◀ to make "X.XX" blink (Possible to change value at this setting mode)
- ③ Press ▲ ◀ to change the value till 1.00
- ④ Press ▲ so that "1.00" doesn't blinking, Act setting is done.
- ⑤ Then press ENT into int purge period, repeat step 2~4 to change the value till 010.
- ⑥ Then press ENT into CLC clean up cycle setting, repeat step 2~4 to change the value till 002.
- ⑦ Then press ENT into Cnt solenoid number setting, repeat step 2~4 to change the value till 010.