

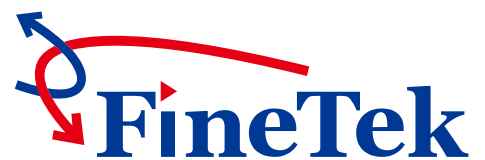

www.fine-tek.com

Electromagnetic Flow Meter



Innovation · Quality · Sharing

FLOW MEASUREMENT FIELD

FineTek is the only inspection institution that owns a Class 2 flow test laboratory in Taiwan. With the most professional R&D and Design Team, it can design and develop high-accuracy electromagnetic flow meters. Moreover, it conducts calibration in Class 1 Flow Laboratory of the National Measurement Laboratory (ITRI Measurement Center), so as to guarantee the flow accuracy on the measurement field.

FineTek's flow laboratory has received certification from the Taiwan Accreditation Foundation and conforms to the regulations of international organizations such as ILAC and APALC. It has the complete ability of uncertainty testing and rating for flow test.



Flow inspection lab with TAF certification ■

Take weighing and parent metering as the foundation for measurement calibration ■

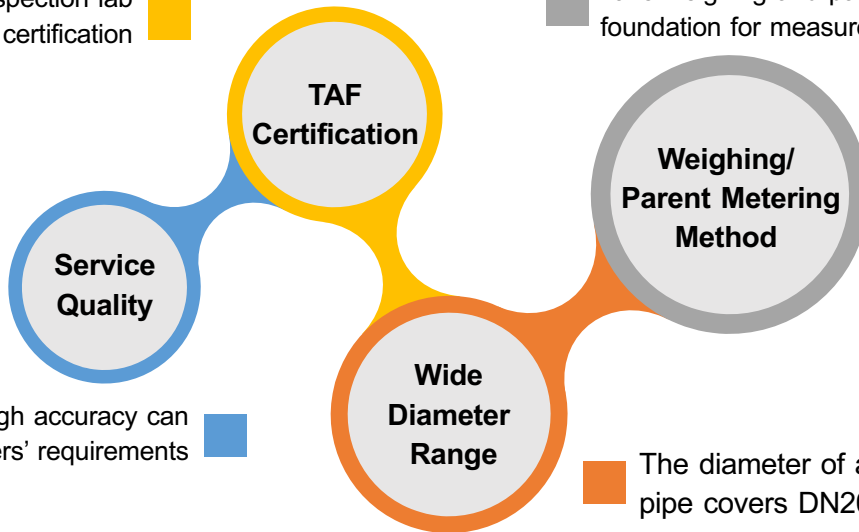

High quality and high accuracy can meet the customers' requirements ■

The diameter of applicable pipe covers DN20~ DN300 ■

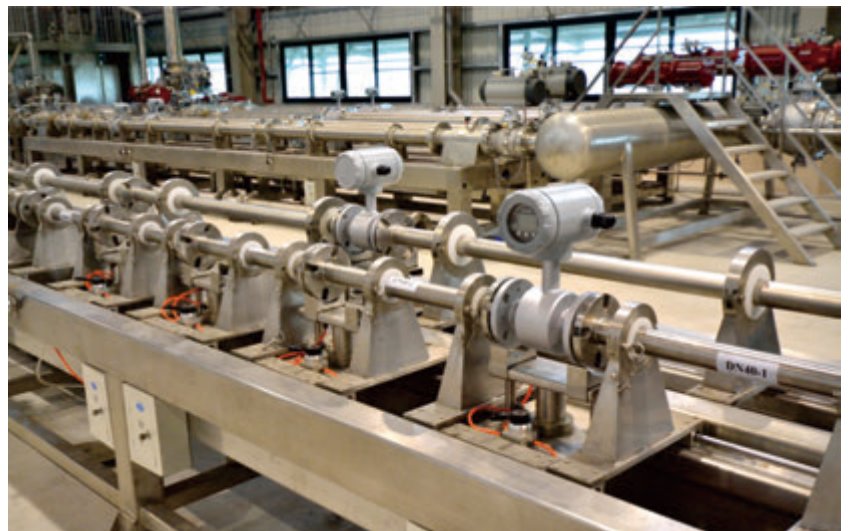
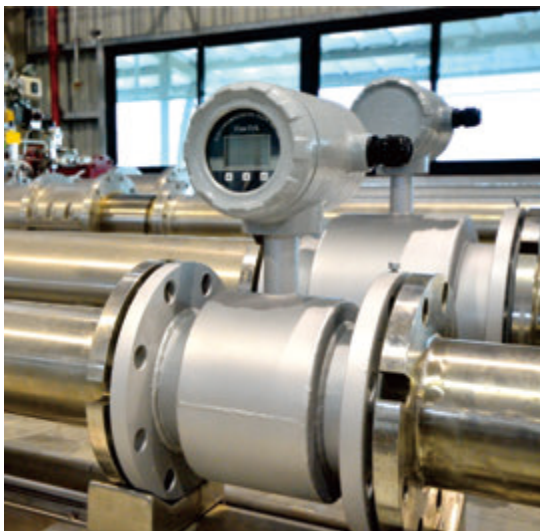

FLOW MEASUREMENT FIELD



PUMP equipment
(The maximum horsepower
is 110KW per unit)



Weighing equipment



Control room & Graphical HMI



Piping system I
(Max capacity for four meters calibration
simultaneously in above system.)



Piping system II
(Maximum diameter is 300mm)



The exclusive report
(Each flow meter has its
own calibration report)

ELECTROMAGNETIC FLOW METER

EPD electromagnetic flow meter is a high-accuracy flow meter manufactured based on the latest international technology. It is widely applied in papermaking, chemical industry, metallurgical industry, drainage, waste water treatment, liquid high-pressure metering, medical care, food, and environmental protection industries. It is used to measure the non-magnetic liquid and plasma in the enclosed pipe.

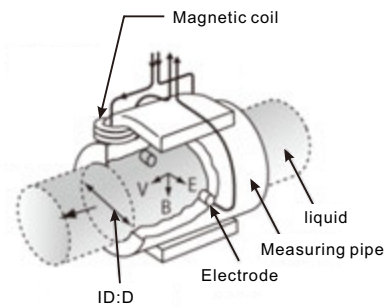
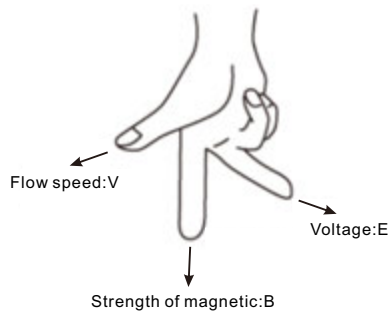

WORKING PRINCIPLE

The working principle of the electromagnetic flow meter is based on the Faraday law of electromagnetic induction. When the conducting liquid flows in the orthogonal direction of the magnetic line direction, it will cut the magnetic lines and generate induced voltage, which shows linear relationship with the flowing speed. Thus, the fluidic volume flow can be calculated.

EPD electromagnetic flow meter is mainly composed of the sensor and transmitter. The measuring tube of the sensor is equipped with the excitation coils upward and downward. The transmitter supplies the excitation current, which generates the magnetic field which goes through the measuring tube once it is powered on. A pair of induction electrodes installed on the inner side of the measuring tube comes in contact with the liquid to guide the induced voltage to the sensor.

APPLICATIONS

- Waste water treatment
- Tapped water purification
- Sewerage
- Sea water desalination module
- Dyeing machines
- Solar energy and PCB wet processing
- Food manufacturing
- Pharmaceutical machines

FEATURES

Low impact on environmental matter

- The measurement results are not affected by the change in liquid density, viscosity, temperature, pressure and conductivity.
- It can be widely applied in the conducting liquids that may contain fiber, solid granules and suspended matters.
- Enclosure protection rating: IP67/NEMA 4X

Wide measurement range & high efficiency

- The wide measurement turndown ratio can be reach 1:100, which can be set randomly and achieve high accuracy for small flow measurement.
- Highly-integrated backlit display of two rows, dual isolation, parameter setting, menu-type operation, memory function, reliable programming, password lock and access, small signal elimination, non-linear correction and two-way measurement.
- Various outputs: Current output 4~20mA, frequency output 2~8KHz and RS485 communication.

Multiple self-diagnosis function

- Power-saving and low fault rate: The measuring tube is without baffle and movable parts, so it won't cause pressure loss and jam.
- Smart self-detection and self-diagnosis function, as well as various alarms

The low installation cost

- It is easy-to-install with low requirements for the straight tube section (Front 5D and rear 2D)
- 2-wire analog output

SPECIFICATION

Item	EPD30 Standard type	EPD34 Remote type
Display	LCM 128*64 pixel backlit type	
Buttons	Tri-button operation	
Communication interface	RS-485 (Modbus) (Optional support for ZigBee Pro wireless transmission)	
Accuracy	±0.5% of reading@1m/s(0.2% optional)	
Medium temperature	-20 ~ 120 °C(PTFE Lining)	
Ambient temperature	-40 ~ 70 °C ¹	
Fluidic conductivity	> 5 uS/cm	
Measuring scope	0.1m/s ~ 10m/s	
Current output accuracy	0.1% of Pulse Output Accuracy Temperature coefficient (100ppm/°C)	
Operating pressure	10Kg/cm ²	
Current output mode	Proactive	
Analog output	4 ~ 20mA	
Maximum load of current output	< 700Ω	
Alarming current	3.6mA or 22 mA	
Frequency output scope	2 ~ 8 KHz	
Pulse width	Automatic (pulse width 50%)	
Pulse mode	NPN transistor output 32vdc/200mA	
Time constant	1~100 s	
Control output (DO)	NPN transistor output 32vdc/200mA ;2-CH	
Control input (DI)	Dry contact ON< 200Ω ; 1,000Ω< OFF ; 1-CH(EPD30),2-CH(EPD34)	
Baud rate	1200 ~ 57600 bps	
Protection rating	IP67 / NEMA 4X	IP68 ² (Transducer) IP67/ NEMA 4X (Transmitter)
Enclosure material	Aluminum alloy	
Input power	AC 100~240V or DC 24V	
Power consumption	< 10W	
Wire inlet specification	M20 x 1.5*2	1/2"NPT *2(Transducer), M20 x 1.5*4(Transmitter)
Excitation mode	Pulse DC	
Vibration regulation	IEC 60068-2-3	
EMC regulation	IEC/EN 61326-1 Class A table2	

¹ It can't display when LCM is lower than -20°C.

² Continuous immersion in 6 meters of water for up to 48 hours.

MATERIAL SELECTION

Electrode material

Electrode material	Anti-corrosion property
Stainless steel (316L)	It is applied in water, sewage and organic and non-organic corrosive medium.
Hastelloy alloy	It is resistant to the corrosion of the medium mixture of oxidizing acid such as Nitric acid, mixed acid or Sulfuric acid. Moreover, it is resistant to the corrosion of the oxidizing salt such as Fe^{2+} 、 Cu^{2+} or other substances containing oxidants such as the salt solution of hypochlorous acid above the ambient temperature and sea water.
Titanium	It is resistant to the corrosion of sea water, various oxides, salt solution of hypochlorous acid, oxidating acid (including fuming Nitric acid) and organic acid and alkane. It is not resistant to the corrosion of pure reducing acid (such as Sulfuric acid and Hydrochloric acid). However, the anti-corrosion property will be greatly degraded if the acid contains some oxidants.
Tantalum	It has excellent corrosion resistance. Its characteristic is similar to glass. In addition to hydrofluoric acid , nitric acid , alkali, it could resist almost all chemical medium (including boiling hydrochloric acid, nitric acid and sulfuric acid below 175 °C). It could not resist corrosion in alkali.

Lining material

Lining material	Main properties	Application scope
PTFE	<ol style="list-style-type: none"> 1. Stable chemical properties, resistant to various acid, alkane, and salt solutions and various organic solvents. It is not tolerant to the corrosion of ClF_3, high-temperature OF_3 and high-speed liquid oxygen and ozone. 2. The anti-abrasion property is average. 	<ol style="list-style-type: none"> 1. -20~120°C 2. Strong corrosive medium such as concentrated acid and alkane.
NBR	<ol style="list-style-type: none"> 1. Excellent flexibility, highly tearing force capability, good wear resistance 2. It is resistant to low concentrations of acid, alkali, salt solution; It is not tolerant the corrosion of oxidizing mediums. 	<ol style="list-style-type: none"> 1. < 80°C 2. Neutral-strong wearing mineral pulp, coal slurry and mud slurry
Neoprene	<ol style="list-style-type: none"> 1. Neutral wearing capability 2. It is resistant to low concentrations of acid, alkali, acid corrosion. 	<ol style="list-style-type: none"> 1. < 80°C 2. Water, Industrial water , Seawater

APPEARANCE AND DIMENSION AND FLANGE CONNECTION DIMENSION STANDARD TYPE

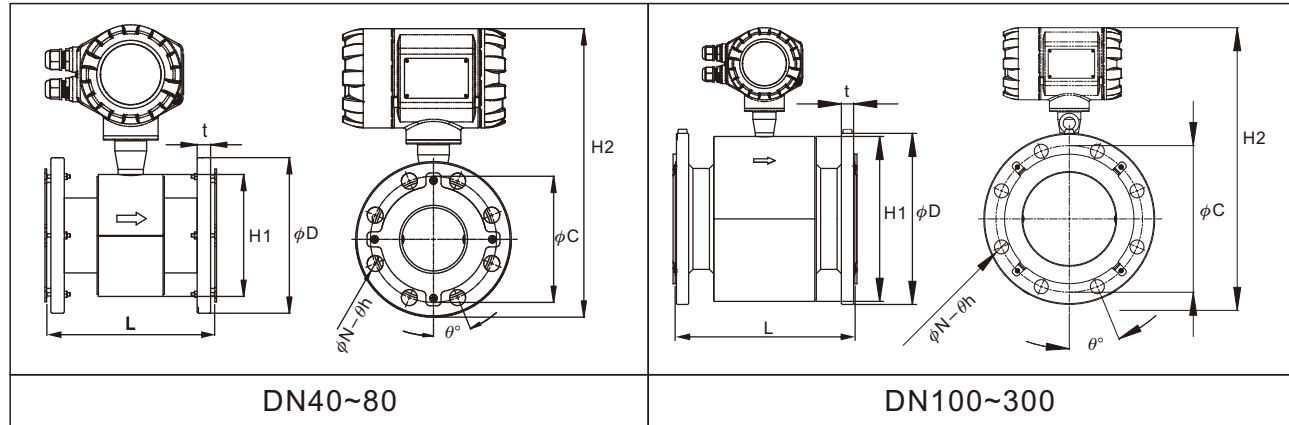

Connection specification		JIS 10K									
Nominal diameter(mm)		40	50	65	80	100	125	150	200	250	300
Lining material		PTFE									
Length	L	200	200	200	200	250	250	300	350	400	500
External diameter	ϕD	140	155	175	185	210	250	280	330	400	445
PCD	ϕC	105	120	140	150	175	210	240	290	355	400
Flange thickness	t	14	14	16	16	16	20	22	22	24	24
Inclined angle of screw hole	θ°	45	45	45	22.5	22.5	22.5	22.5	15	15	11.25
Diameter of screw hole	θh	19	19	19	19	19	19	23	23	25	25
Quantity of screw holes	N	4	4	4	8	8	8	8	12	12	16
Height of sensor casing	H1	125	125	145	145	195	195	270	305	365	406
Total height	H2	315	322	342	347	384.5	404.5	467	506	572	616
Weight (kg)		6.8	7.68	8.98	9.87	12.9	17.5	23.51	33.23	54.03	69.55

Connection specification		JIS 20K									
Nominal diameter(mm)		40	50	65	80	100	125	150	200	250	300
Lining material		PTFE									
Length	L	200	200	200	200	250	250	300	350	400	500
External diameter	ϕD	140	155	175	200	225	270	305	350	430	480
PCD	ϕC	105	120	140	160	185	225	260	305	380	430
Flange thickness	t	18	18	20	22	24	26	28	30	34	36
Inclined angle of screw hole	θ°	45	22.5	22.5	22.5	22.5	22.5	15	15	15	11.25
Diameter of screw hole	θh	19	19	23	23	23	25	25	25	27	27
Quantity of screw holes	N	4	8	8	8	8	8	12	12	12	16
Height of sensor casing	H1	125	125	145	145	195	195	270	305	365	406
Total height	H2	314.5	322	342	354.5	392	414.5	478	514	585	632
Weight (kg)		7.08	7.72	8.98	12.25	16.42	23.56	31.03	43.37	74.23	94.15

Remarks: For DN40~DN80, the lining protective ring is 2mm, so the total length of the flow meter shall be increased by L+4mm.
 For DN100~DN300, the lining protective ring is 0.5mm, so the total length of the flow meter shall be increased by L+1mm;
 total length (L) tolerance is ± 3 mm, total height (H2) tolerance is ± 5 mm

APPEARANCE AND DIMENSION AND FLANGE CONNECTION DIMENSION STANDARD TYPE

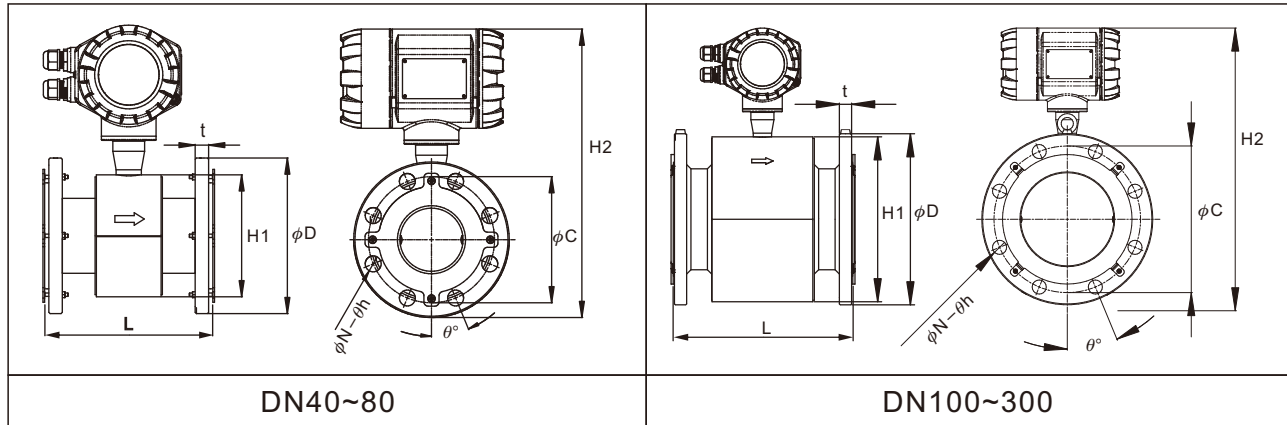

Connection specification		JIS 7.5K							
Nominal diameter(mm)		50	80(75)	100	125	150	200	250	300
Lining material		PTFE							
Length	L	200	200	250	250	300	350	400	500
External diameter	ϕD	155	211	238	263	290	342	410	464
PCD	ϕC	120	168	185	225	247	299	360	414
Flange thickness	t	18	21	24	26	23	24	26	28
Inclined angle of screw hole	θ°	45	45	45	30	30	22.5	22.5	18
Diameter of screw hole	θh	19	19	19	19	19	19	23	23
Quantity of screw holes	N	4	4	4	6	6	8	8	10
Height of sensor casing	H1	125	145	195	195	270	305	365	406
Total height	H2	322	360	399	411	472	511	577	625
Weight (kg)		7.68	12.45	15.82	19.55	25.63	36.83	55.63	74.95

Remarks: For DN40~DN80, the lining protective ring is 2mm, so the total length of the flow meter shall be increased by L+4mm.
 For DN100~DN300, the lining protective ring is 0.5mm, so the total length of the flow meter shall be increased by L+1mm;
 total length (L) tolerance is ± 3 mm, total height (H2) tolerance is ± 5 mm

APPEARANCE AND DIMENSION AND FLANGE CONNECTION DIMENSION STANDARD TYPE

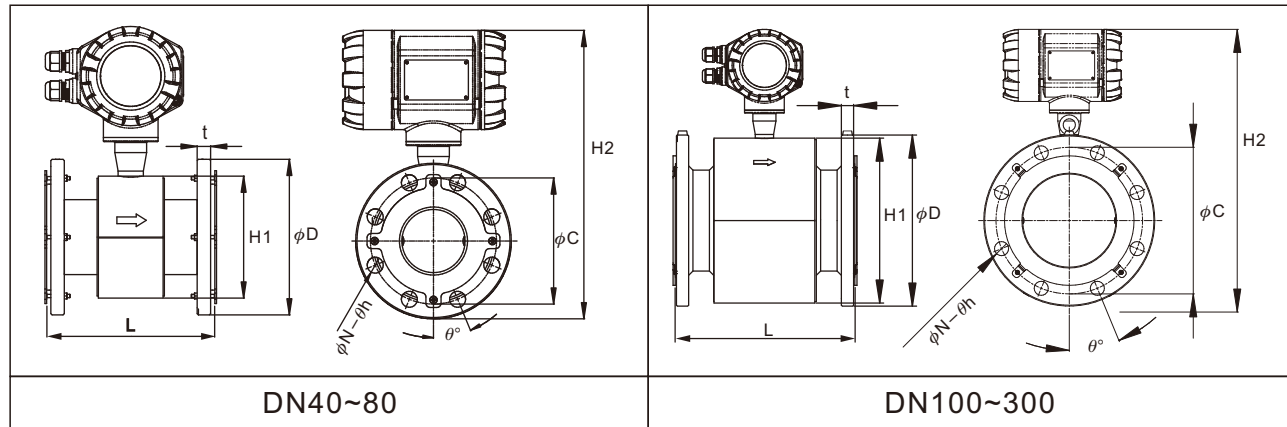

Connection specification		ANSI 150Lbs									
Nominal diameter(mm)		40	50	65	80	100	125	150	200	250	300
Lining material		PTFE									
Length	L	200	200	200	200	250	250	300	350	400	500
External diameter	ϕD	127	152	178	190	229	254	279.4	342.9	406.4	482.6
PCD	ϕC	98.4	120.6	139.7	152.4	190.5	215.9	241.3	298.4	361.9	431.8
Flange thickness	t	15.9	17.4	20.6	22.2	22.2	22.2	23.8	27	28.6	30.2
Inclined angle of screw hole	θ°	45	45	45	45	22.5	22.5	22.5	22.5	15	15
Diameter of screw hole	θh	15.9	19	19	19	19	22.2	22.2	22.2	25.4	25.4
Quantity of screw holes	N	4	4	4	4	8	8	8	8	12	12
Height of sensor casing	H1	125	125	145	145	195	195	265	305	365	406
Total height	H2	308	321	344	350	394	407	464	511	575	633
Weight (kg)		6.48	8.32	10.78	12.25	17.82	20.96	27.03	44.17	67.23	99.55

Connection specification		ANSI 300Lbs									
Nominal diameter(mm)		40	50	65	80	100	125	150	200	250	300
Lining material		PTFE									
Length	L	200	200	200	200	250	250	300	350	400	500
External diameter	ϕD	156	165	190	210	254	279	317.5	381	444.5	520.7
PCD	ϕC	114.3	127	149.2	168.3	200	235	269.9	330.2	387.35	450.9
Flange thickness	t	19	20.6	23.8	27	30.2	33.3	34.9	39.7	46	49.2
Inclined angle of screw hole	θ°	45	22.5	22.5	22.5	22.5	22.5	15	15	11.3	11.3
Diameter of screw hole	θh	22.2	19	22.2	22.2	22.2	22.2	22.2	25.4	28.6	31.8
Quantity of screw holes	N	4	8	8	8	8	8	12	12	16	16
Height of sensor casing	H1	125	125	145	145	195	195	265	305	365	406
Total height	H2	323	327	350	360	407	419	481	528	592	650
Weight (kg)		9.08	10.32	12.78	16.45	26.62	32.96	43.83	69.17	100.43	146.6

Remarks: For DN40~DN80, the lining protective ring is 2mm, so the total length of the flow meter shall be increased by L+4mm.
 For DN100~DN300, the lining protective ring is 0.5mm, so the total length of the flow meter shall be increased by L+1mm;
 total length (L) tolerance is ± 3 mm, total height (H2) tolerance is ± 5 mm

APPEARANCE AND DIMENSION AND FLANGE CONNECTION DIMENSION STANDARD TYPE

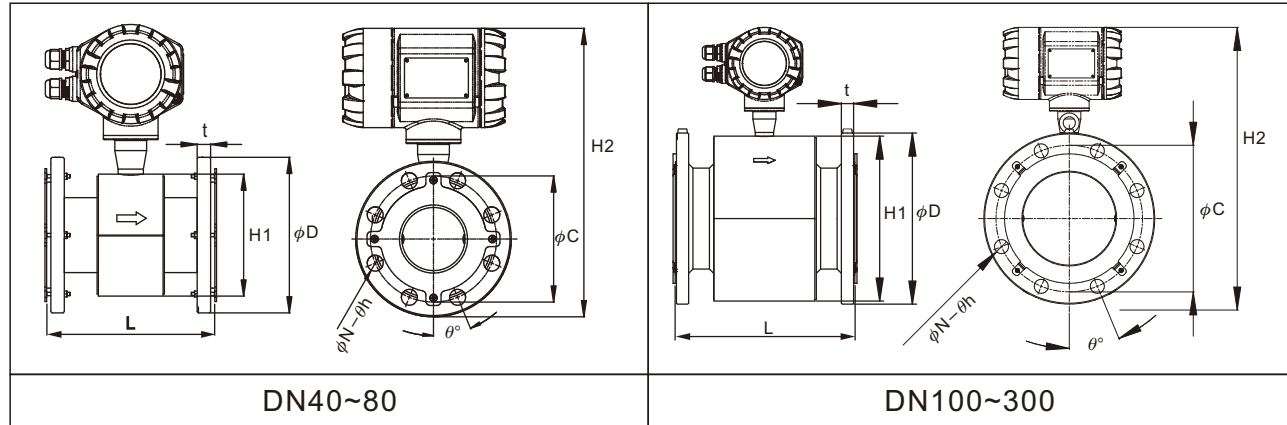

Connection specification		DIN PN40				DIN PN16					
Nominal diameter(mm)		40	50	65	80	65	80	100	125	150	200
Lining material		PTFE									
Length	L	200	200	200	200	200	200	250	250	300	350
External diameter	ϕD	150	165	185	200	185	200	220	250	285	340
PCD	ϕC	110	125	145	160	145	160	180	210	240	295
Flange thickness	t	18	20	22	24	18	20	20	22	22	24
Inclined angle of screw hole	θ°	45	45	22.5	22.5	45	22.5	22.5	22.5	22.5	15
Diameter of screw hole	θh	18	18	18	18	18	18	18	18	22	22
Quantity of screw holes	N	4	4	8	8	4	8	8	8	8	12
Height of sensor casing	H1	125	125	145	145	145	145	195	195	265	305
Total height	H2	320	327	347	355	347	355	390	405	470	510
Weight (kg)		7.08	7.72	8.98	12.25	8.58	11.65	15.62	20.96	28.23	39.97

Connection specification		DIN PN10		
Nominal diameter(mm)		200	250	300
Lining material		PTFE		
Length	L	350	400	500
External diameter	ϕD	340	395	445
PCD	ϕC	295	350	400
Flange thickness	t	24	26	26
Inclined angle of screw hole	θ°	22.5	15	15
Diameter of screw hole	θh	22	22	22
Quantity of screw holes	N	8	12	12
Height of sensor casing	H1	305	365	406
Total height	H2	510	568	637
Weight (kg)		33.23	54.03	69.55

Remarks: For DN40~DN80, the lining protective ring is 2mm, so the total length of the flow meter shall be increased by L+4mm. For DN100~DN300, the lining protective ring is 0.5mm, so the total length of the flow meter shall be increased by L+1mm; total length (L) tolerance is ± 3 mm, total height (H2) tolerance is ± 5 mm

APPEARANCE AND DIMENSION AND FLANGE CONNECTION DIMENSION REMOTE TYPE

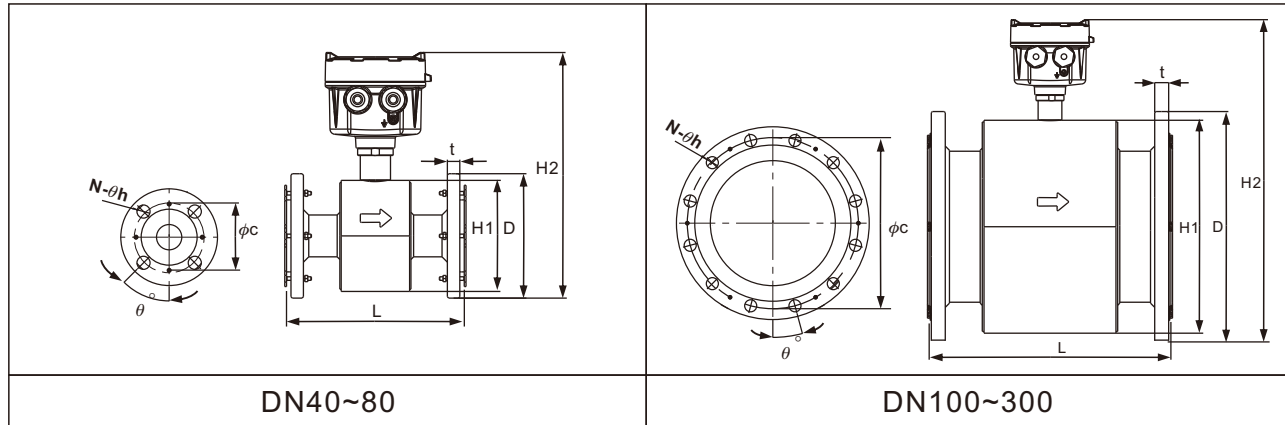

Connection specification		JIS 10K									
Nominal diameter(mm)		40	50	65	80	100	125	150	200	250	300
Lining material		PTFE									
Length	L	200	200	200	200	250	250	300	350	400	500
External diameter	ϕD	140	155	175	185	210	250	280	330	400	445
PCD	ϕC	105	120	140	150	175	210	240	290	355	400
Flange thickness	t	14	14	16	16	16	20	22	22	24	24
Inclined angle of screw hole	θ°	45	45	45	22.5	22.5	22.5	22.5	15	15	11.25
Diameter of screw hole	θh	19	19	19	19	19	19	23	23	25	25
Quantity of screw holes	N	4	4	4	8	8	8	8	12	12	16
Height of sensor casing	H1	125	125	145	145	195	195	270	305	365	406
Total height	H2	276.4	283.9	303.9	308.9	346.4	366.4	429	468	534	578
Weight (kg)*2	-	5.25	6.13	7.43	8.32	11.35	15.95	21.96	31.68	52.48	68.00

Connection specification		JIS 20K									
Nominal diameter(mm)		40	50	65	80	100	125	150	200	250	300
Lining material		PTFE									
Length	L	200	200	200	200	250	250	300	350	400	500
External diameter	ϕD	140	155	175	200	225	270	305	350	430	480
PCD	ϕC	105	120	140	160	185	225	260	305	380	430
Flange thickness	t	18	18	20	22	24	26	28	30	34	36
Inclined angle of screw hole	θ°	45	22.5	22.5	22.5	22.5	22.5	15	15	15	11.25
Diameter of screw hole	θh	19	19	23	23	23	25	25	25	27	27
Quantity of screw holes	N	4	8	8	8	8	8	12	12	12	16
Height of sensor casing	H1	125	125	145	145	195	195	270	305	365	406
Total height	H2	276.4	283.9	303.9	316.4	353.9	376.4	440	476	547	594
Weight (kg)*2	-	5.53	6.17	7.43	10.7	14.87	22.01	29.48	41.82	72.68	92.60

*1: Remarks: For DN40~DN80, the lining protective ring is 2mm, so the total length of the flow meter shall be increased by L+4mm.
For DN100~DN300, the lining protective ring is 0.5mm, so the total length of the flow meter shall be increased by L+1mm;
total length (L) tolerance is ± 3 mm, total height (H2) tolerance is ± 5 mm

*2: To shows the weight of transducer only. Not include the weight of transmitter 2.06kg

APPEARANCE AND DIMENSION AND FLANGE CONNECTION DIMENSION REMOTE TYPE

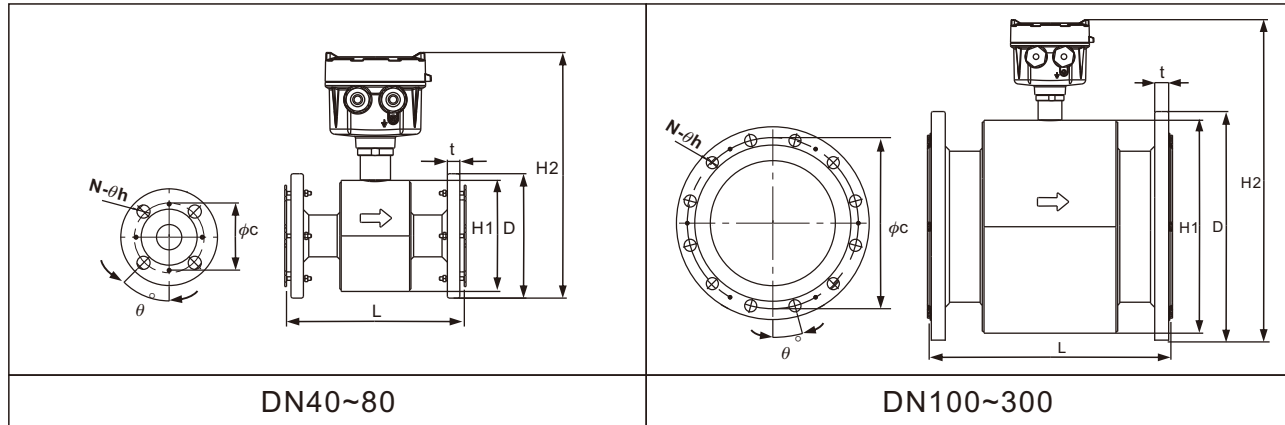

Connection specification		ANSI 150 Lbs									
Nominal diameter(mm)		40	50	65	80	100	125	150	200	250	300
Lining material		PTFE									
Length	L	200	200	200	200	250	250	300	350	400	500
External diameter	ϕD	127	152	178	190	229	254	279.4	342.9	406.4	482.6
PCD	ϕC	98.4	120.6	139.7	152.4	190.5	215.9	241.3	298.4	361.9	431.8
Flange thickness	t	15.9	17.4	20.6	22.2	22.2	22.2	23.8	27	28.6	30.2
Inclined angle of screw hole	θ°	45	45	45	45	22.5	22.5	22.5	22.5	15	15
Diameter of screw hole	θh	15.9	19	19	19	19	22.2	22.2	22.2	25.4	25.4
Quantity of screw holes	N	4	4	4	4	8	8	8	8	12	12
Height of sensor casing	H1	125	125	145	145	195	195	265	305	365	406
Total height	H2	322	335	358	364	408	421	478	525	589	647
Weight (kg)*2	-	4.93	6.77	9.23	10.7	16.27	19.41	25.48	42.62	65.68	98

Connection specification		ANSI 300 Lbs									
Nominal diameter(mm)		40	50	65	80	100	125	150	200	250	300
Lining material		PTFE									
Length	L	200	200	200	200	250	250	300	350	400	500
External diameter	ϕD	156	165	190	210	254	279	317.5	381	444.5	520.7
PCD	ϕC	114.3	127	149.2	168.3	200	235	269.9	330.2	387.35	450.85
Flange thickness	t	19	20.6	23.8	27	30.2	33.3	34.9	39.7	46	49.2
Inclined angle of screw hole	θ°	45	22.5	22.5	22.5	22.5	22.5	15	15	11.3	11.3
Diameter of screw hole	θh	22.2	19	22.2	22.2	22.2	22.2	22.2	25.4	28.6	31.8
Quantity of screw holes	N	4	8	8	8	8	8	12	12	16	16
Height of sensor casing	H1	125	125	145	145	195	195	265	305	365	406
Total height	H2	337	341	364	374	421	433	495	542	606	664
Weight (kg)*2	-	9.08	10.32	12.78	16.45	26.62	32.96	42.28	67.62	98.88	145

*1: Remarks: For DN40~DN80, the lining protective ring is 2mm, so the total length of the flow meter shall be increased by L+4mm.
For DN100~DN300, the lining protective ring is 0.5mm, so the total length of the flow meter shall be increased by L+1mm;
total length (L) tolerance is ± 3 mm, total height (H2) tolerance is ± 5 mm

*2: To shows the weight of transducer only. Not include the weight of transmitter 2.06kg

APPEARANCE AND DIMENSION AND FLANGE CONNECTION DIMENSION REMOTE TYPE

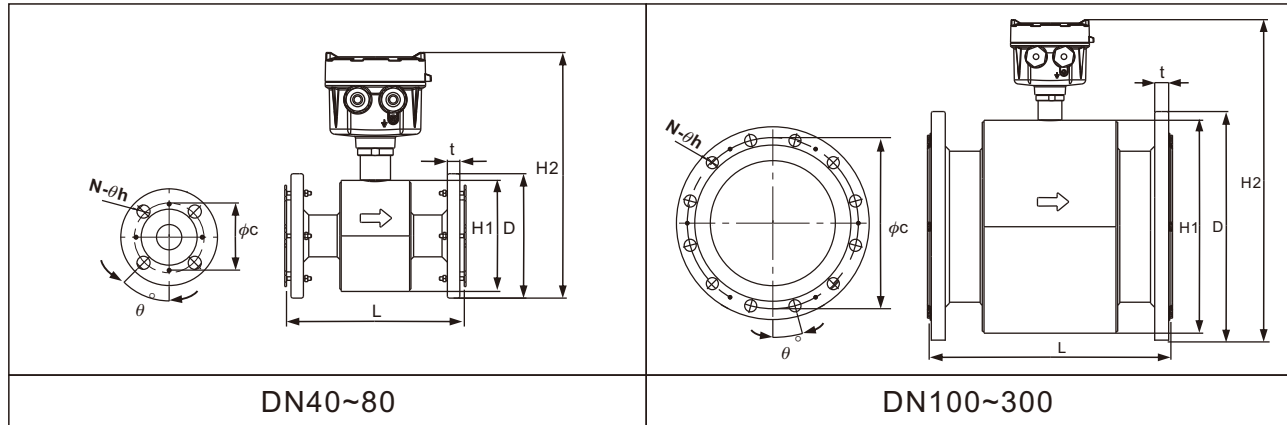

Connection specification		DIN PN40				DIN PN16					
Nominal diameter(mm)		40	50	65	80	65	80	100	125	150	200
Lining material		PTFE									
Length	L	200	200	200	200	200	200	250	250	300	350
External diameter	ϕD	150	165	185	200	185	200	220	250	285	340
PCD	ϕC	110	125	145	160	145	160	180	210	240	295
Flange thickness	t	18	20	22	24	18	20	20	22	22	24
Inclined angle of screw hole	θ°	45	45	22.5	22.5	45	22.5	22.5	22.5	22.5	15
Diameter of screw hole	θh	18	18	18	18	18	18	18	18	22	22
Quantity of screw holes	N	4	4	8	8	4	8	8	8	8	12
Height of sensor casing	H1	125	125	145	145	145	145	195	195	265	305
Total height	H2	334	341	361	369	361	369	404	419	484	524
Weight (kg)*2		5.53	6.17	7.43	10.70	7.03	10.70	14.07	19.41	26.68	38.42

Connection specification		DIN PN10		
Nominal diameter(mm)		200	250	300
Lining material		PTFE		
Length	L	350	400	500
External diameter	ϕD	340	395	445
PCD	ϕC	295	350	400
Flange thickness	t	24	26	26
Inclined angle of screw hole	θ°	22.5	15	15
Diameter of screw hole	θh	22	22	22
Quantity of screw holes	N	8	12	12
Height of sensor casing	H1	305	365	406
Total height	H2	524	582	651
Weight (kg)*2		31.68	52.48	68

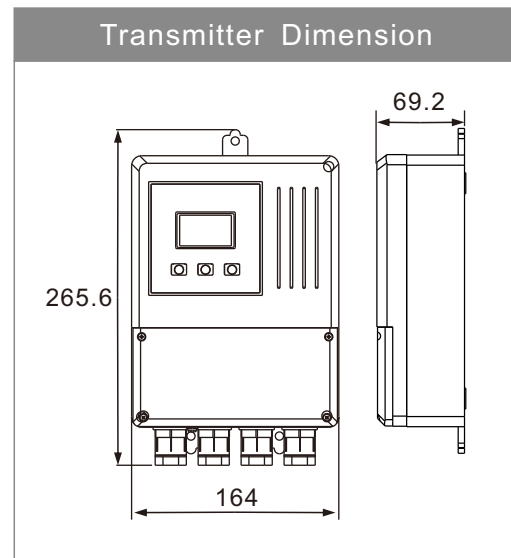

*1: Remarks: For DN40~DN80, the lining protective ring is 2mm, so the total length of the flow meter shall be increased by L+4mm.
For DN100~DN300, the lining protective ring is 0.5mm, so the total length of the flow meter shall be increased by L+1mm;
total length (L) tolerance is ± 3 mm, total height (H2) tolerance is ± 5 mm

*2: To shows the weight of transducer only. Not include the weight of transmitter 2.06kg

PIPE DIAMETER, FLOW RANGE AND ACCURACY SELECTION

Pipe diameter (mm)	Flow range (m ³ /h)	
	Flowing speed 0.1~1.0m/s	Flowing speed 1.0~10m/s
40	0.45~4.5	4.5~45.2
50	0.71~7.1	7.1~71
65	1.19~11.9	11.9~119
80	1.81~18.1	18.1~181
100	2.83~28.3	28.3~283
125	4.42~44.2	44.2~442
150	6.36~63.6	63.6~636
200	11.3~113	113~1130
250	17.7~177	177~1770
300	25.4~254	254~2540

DN (mm)	Q4 (m ³ /h)	Q3 (m ³ /h)	Q2 (m ³ /h)	Q1 (m ³ /h)
Ratio	5	1.25	1.6	160
40	50	40	0.40	0.25
50	78.75	63	0.63	0.394
65	125	100	1.01	0.63
80	200	160	1.60	1.00
100	313	250	2.52	1.57
125	500	400	4.00	2.50
150	788	630	6.31	3.94
200	1250	1000	10.00	6.25
250	2000	1600	16.00	10.00
300	3125	2500	25.01	15.63

OIML Accuracy class & tolerance

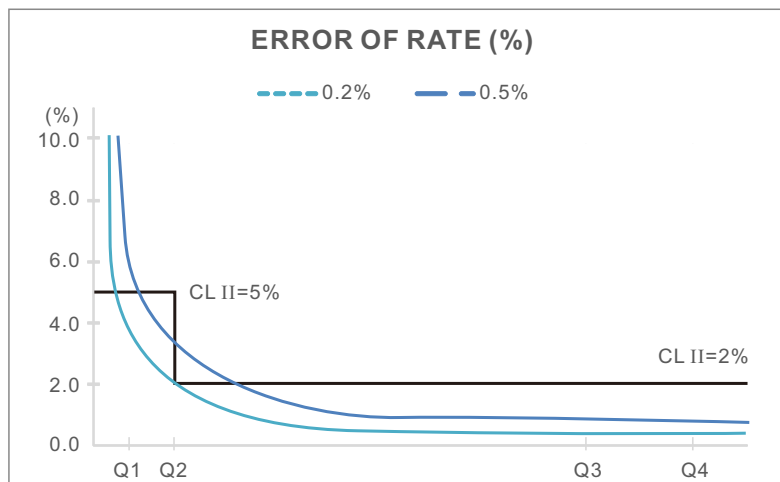

Type	EPD 3x
Nominal diameter(DN)	50
Q_3/Q_1 *	160
Q_2/Q_1	1,6
Q_1 (m ³ /h)	0.394
Q_2 (m ³ /h)	0.63
Q_3 (m ³ /h)	63
Q_4 (m ³ /h)	78.75

INSTALLATION INSTRUCTIONS

1. The flow meter must be free from strong electromagnetic field. The magnetic intensity of the flow meter installation site must be smaller than 400A/m (It should not be installed near large motors or transformers).
2. It should be installed at the lower point and the vertically upward point of the horizontal pipe. Don't install it at the highest point and the vertically downward point of the pipe.

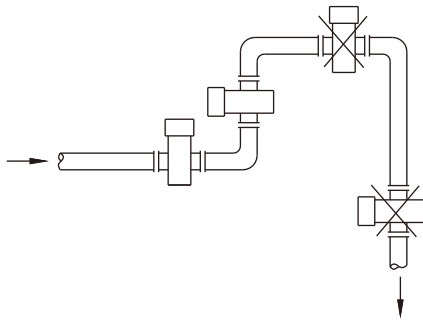

3. It should be installed at the rising point of the pipe.



4. It should be installed at the lower point of the pipe when it is installed on the pipe with opening for drainage.

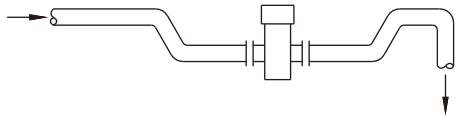

5. If the pipe gap exceeds 5m, the air release valve should be installed at the downstream of the sensor. The downstream of the sensor should have some back pressure.

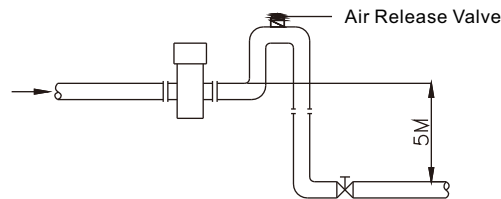

6. The control valve and cut valve should be installed at the downstream of the sensor rather than the upstream.

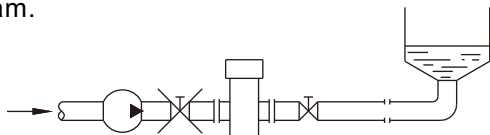

7. The sensor should be installed at the pump outlet rather than the inlet.

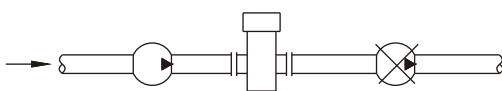

8. The fluidic must flow towards the arrow direction of the flow meter.
9. The axial line of the measuring electrode must be approximate to the horizontal direction (The angle of from the horizontal direction).
10. The measuring pipe must be completely filled with liquid.

INSTALLATION INSTRUCTIONS

11. The straight tube section is required to be at least 5D (internal diameter of the flow meter) on the front side, and at least 2D on the rear side.

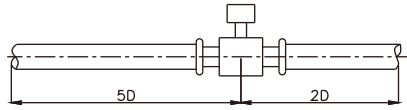

12. When measuring the mixture of different media, the distance between the mixing point and the flow meter must be 30D at least.

13. For convenient cleaning and maintenance of the flow meter, a bypass pipe must be installed.

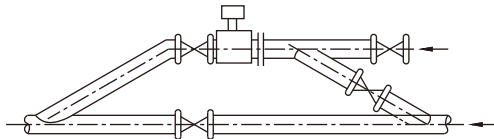

14. When installing the sensor, it should ensure that the measuring pipe and the process pipe must be on the same axial line. For the flow meter with the pipe meter of 50mm or below, the axial line deviation should not exceed 2mm. For those of DN65~DN150, the axial line deviation should not exceed 3mm. For those of \geq DN200, the axial line deviation should not exceed 4mm.

15. The shim installed between the flanges should have excellent anti-corrosion property. The shim should not intrude in the pipe, which will affect the fluidic in the pipe.

16. The sensor and transmitter should be equipped with high-quality independent grounding wire (The section area of the copper core is 1.6mm²). The grounding resistance should be $<10\Omega$. If the grounding is poor, it won't work normally. The grounding ring is needed if the pipe connecting with the sensor is insulating, and the material of the grounding ring should be the same as that of the electrode. If the test medium is abrasive, the neck grounding ring should be selected.

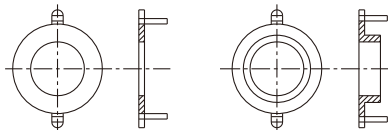

- 16.1 It is for installing the flow meter on the metal pipe not coated with insulating layer internally.

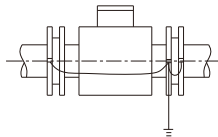

- 16.2 When installing the flow meter on the protective pipe of the cathode, the pipe with the protection of electrolytic corrosion generally has insulating walls and protruding sides. Thus, during installation, the grounding ring and the flanges on the pipe should be insulating.

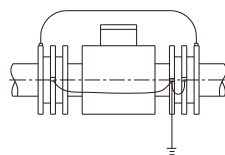

- 16.3 When installing the flow meter on the plastic pipe or the pipe with insulating coating material, paints or lining, grounding rings on both ends of the sensor should be installed.

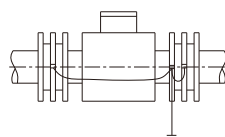

MODEL NUMBER / ORDER CODE COMPARISON TABLE

ORDERING INFORMATION

Model Number	Order Code
EPD30	EPD10000-A
EPD34	EPD10400-A

EPD1 ⁰⁵ ⁰⁶ 0 0 - A ¹⁰ ¹¹ ¹² ¹³ ¹⁴ ¹⁵ ¹⁶ ¹⁷ ¹⁸ ¹⁹ ²⁰ ²¹ A ²³ ²⁴ ²⁵ ²⁶ ²⁷ ²⁸

⁰⁵ ⁰⁶ Type

- 00: Standard
- 04: Remote type

¹⁰ ¹¹ ¹² Pipe diameter

- 040: 40mm 125: 125mm
- 050: 50mm 150: 150mm
- 065: 65mm 200: 200mm
- 080: 80mm 250: 250mm
- 100: 100mm 300: 300mm

¹³ ¹⁴ ¹⁵ Connection specification

- C48: ANSI B16.5 Class 150
- C49: ANSI B16.5 Class 300
- A41: JIS B2220 7.5K
- A42: JIS B2220 10K
- A45: JIS B2220 20K
- D57: DIN 2501 PN10
- D58: DIN 2501 PN16
- D60: DIN 2501 PN40

¹⁶ ¹⁷ Casing and flange

- MD: Carbon steel
- MA: SUS304
- MC: SUS316L

¹⁸ ¹⁹ Lining material

- 08: Neoprene
- 21: PTFE
- 37: NBR

(Next page)

ORDERING INFORMATION

EPD1 ⁰⁵ ⁰⁶ 0 0 - A ¹⁰ ¹¹ ¹² ¹³ ¹⁴ ¹⁵ ¹⁶ ¹⁷ ¹⁸ ¹⁹ ²⁰ ²¹ A ²³ ²⁴ ²⁵ ²⁶ ²⁷ ²⁸

⑳㉑ Electrode material

- MC: SUS316L
- MF: Titanium
- MK: Tantalum
- MJ: Hastelloy alloy(C-276)

㉓ Power supply

- A: 100~240Vac, 50/60Hz
- D: 24Vdc

㉔ Accuracy

- F: 0.5%
- G: 0.3%
- H: 0.2%

㉕㉖ Grounding material

- 00: None
- MA: SUS304
- MC: SUS316L
- MF: Titanium
- MK: Tantalum
- MJ: Hastelloy alloy(C-276)

㉗㉘ Cable length

- 00: None(Only available for standard type)
- 10: 10 M(Remote type standard)
- 15: 15 M
- 20: 20 M
- ⋮
- 95: 95 M
- A0: 100 M

SETTING VALUES

Main Menu	Sub Menu	Unit	Default	Setting Range
Fast Set(0)	Device Tag Num (1.1)			
	Zero Adj. (2.1)			
	Flow Span (1.5)			
	Flow Unit (1.4)			
	Low cutoff (2.4)			
	Damping Time (3.1)			
	Pulse Out Unit (3.3)			
	Total Reset (1.9)			

The parameter is linking from standard menu

Main Menu	Sub Menu	Unit	Default	Setting Range
Basic Set (1)	Device Tag Num (1.1)	none	00001	00001~65535
	Measure Type (1.2)	-	Water	Water
	Tube Size (1.3)	mm	actual	10,15,25,32,40,50,65,80,100 125,150,200,250,300,350,400,450,500
	Flow Unit (1.4)	-	m ³ /h	L/(s,min,h), m ³ /(s,min,h), gal/(s,min,h), kg(s,min,h), Ton(s,min,h) (Flow rate* Liquid density = weight) "L/s", "L/m", "L/h", "m ³ /s", "m ³ /m", "m ³ /h", "gal/s", "gal/m", "gal/h", "kg/s", "kg/m", "kg/h", "Ton/s", "Ton/m", "Ton/h", "m ³ /d"
	Flow Span (1.5)	=Flow Rate Unit	$(5m/s) \times (\text{Diameter}/2)^2 \times \pi \times \text{Unit of Flow Forward}$	$(0.1 \sim 10.0m/s) \times (\text{Diametermm}/2)^2 \times \pi \times \text{Unit of Flow Forward}$
	Direction (1.6)	dir	Forward	Forward,Reverse
	Total Unit (1.7)	-	m ³	Liter,gal,m ³ ,kg,Ton
	Total Mode (1.8)	none	Forward	Forward,Reverse,Bi-direction
	Total Reset (1.9)	none	Cancel	Cancel,Accept

Main Menu	Sub Menu	Unit	Default	Setting Range
Advanced Set (2)	Zero Adj. (2.1)	m/s	actual	-0.5000~+0.5000
	K-Factor (2.2)	none	1.000	0.000~3.000
	Density (2.3)	g/cm ³	1.0000	0.0001~9.9999
	Low cutoff (2.4)	%	0.5	0.00~100.00
	Fwd. Init. (2.5)	=Total Unit	0	0~9999999999
	Rev. Init.(2.6)	=Total Unit	0	0~9999999999

SETTING VALUES

Main Menu	Sub Menu	Unit	Default	Setting Range
I/O Signal Set (3)	Damping Time (3.1)	second (s)	3	0~100
	Pulse Out Mode (3.2)	none	Pulse NO	Pulse NO, Pulse NC, Frequency
	Pulse Out Unit (3.3)	Unit/pulse	0.1 L	0.001~100(L,gal,m ³ ,g,kg,Ton) m ³ /pulse,gal/pulse,m ³ /pulse g/pulse,kg/pulse,Ton/pulse
	Max. Freq. (3.4)	Hz,kHz	2K	1~8K (00.000)
	Curr. Mode (3.5)	none	4-20	4-20,0-20
	4mA Fine-Tune (3.6)	count	0	-5000~5000
	20mA Fine-Tune (3.7)	count	0	-5000~5000
	Input1 Func. (3.8)	N/A	None	None, Total Reset
	Input1 Type (3.9)	N/A	NO	NO,NC
	Filter Variation (3.10)	m/s	1	0.000~10.000
	Filter Weight (3.11)	%	10	0~100

Main Menu	Sub Menu	Unit	Default	Setting Range
Alarm Set (4)	Max. Flow (4.1)	Flow Rate Unit	Max.	Max. Flow Rate
	Min. Flow (4.2)	Flow Rate Unit	Min.	Min. Flow Rate
	Empty Tube Set (4.3)	N/A	Disable	Enable, Disable
	Output 1 Func. (4.4)	N/A	Max. Flow Rate	Max. Flow Rate, Min. Flow Rate, Empty Tube, System Alarm
	Output 1 Type (4.5)	N/A	No	NO,NC
	Output 2 Func. (4.6)	N/A	Min. Flow Rate	Max. Flow Rate, Min. Flow Rate, Empty Tube, System Alarm
	Output 2 Type (4.7)	N/A	No	NO,NC
	Curr. Func. (4.8)	N/A	None	Empty Tube, System Alarm
	Alarm Curr. (4.9)	mA	3.6	3.6,3.8,20.5,22
	Temp. Alarm. (4.10)	N/A	1	0:OFF, 1:ON

SETTING VALUES

Main Menu	Sub Menu	Unit	Default	Setting Range	
System Set (5)	Language (5.1)	N/A	English	English, 繁中, 简中	
	System Info.(5.2)	N/A	Actual	(Normal, Empty)	
		m/s	Actual	N/A	
		kΩ	Actual	N/A	
		N/A	Actual	0000 0000 ~ FFFF FFFF	
	Self-Test (5.3)	N/A	Cancel	Normal, Circuit Fail ,Excitation Fail, Amb. Temp, Electrode Coating	
	Analogy Input (5.4)	N/A	0000	0~9999	
		N/A	1000	0~9999	
		N/A	Kpa	None, Kpa, Mpa, Psi, Bar, °C, °F	
		N/A	1	0~3	
	ModBus Comm. (5.5)	N/A	1	1~255	
		N/A	BPS	9600	1200,2400,4800,9600,19200 38400,57600
		N/A	8	8,9	
	Recovery Default (5.6)	N/A	none	none,odd,even	
		N/A	1	1,2	
		N/A	Cancel	Cancel, Accept	
	Mains Frequency (5.7)	Hz	50	50, 60	
LCM Contrast Brightness(5.8)	N/A	32	15~40		

Main Menu	Sub Menu	Unit	Default	Setting Range
Simulation (6)	Flow Speed (6.1)	m/s	0	-10 ~ 10
	Flow Rate (6.2)	Flow Rate Unit	0	0~max.
	Output Curr. (6.3)	mA	4mA	3.6~22
	Output Freq. (6.4)	Hz(pulse/sec)	2	8000
	Output1 Status (6.5)	N/A	OFF	ON/OFF
	Output2 Status (6.6)	N/A	OFF	ON/OFF
	Input1 Status (6.7)	N/A	Actual	ON/OFF
	Input Curr. (6.8)	N/A	Actual	0~24mA

Main Menu	Sub Menu	Unit	Default	Setting Range
System Log (7)	Date Set (7.1)	actual		year : 17~99, month : 01~12, day : 01~31
	Time Set (7.2)	actual		hour : 00~23, minute : 00~59, sec : 00~59
	System Log Info (7.3)	actual		N/A

Main Menu	Sub Menu	Unit	Default	Setting Range
Infomation (8)	F.W. Version(8.1)		actual	

APPLICATION DEMO



Pharmaceutical



Pharmacy



Beverage



Electronics



Food & Beverage



Incinerator



Mining



Plastic

TUCHENG PLANT/YILAN PLANT



EPD APPLICATION / ORDER FORM

Company Profile

Company Name: _____ Contact Person: _____

E-mail: _____ Phone: _____ Tax: _____

Application

Medium: _____ Temperature: _____ Sanitary Degree Request: Yes NO

Conductivity: _____ Viscosity: _____

Diameter of Tube (DN) : _____ Accuracy Request(%): _____ Ambient Temp.: _____

Normal Flow Rate(m³/h): _____ Max. Flow Rate(m³/h): _____ Min. Flow Rate(m³/h): _____

Connection Spec: _____ Connection Material**: _____

Pressure (Kg/cm²): _____ Max. Static Pressure (Kg/cm²): _____ **SUS304, SUS316, SUS316L

Lining Material*: _____ Electrode Material***: _____

* PTFE · NBR · Neoprene

***SUS316 · Hastelloy Alloy · Titanium · Tantalum

Power: 110Vac 220Vac 24Vdc

Output: 4-20mA/Pulse(freq) RS-485/Modbus

Grounding: NO YES

Installation Direction: Horizontal Vertical

Vibration Inside Tube: NO YES

Strong Magnetic Nearby: NO YES

Explosion Proof: NO YES

Explosion Proof Code: _____

Global Network

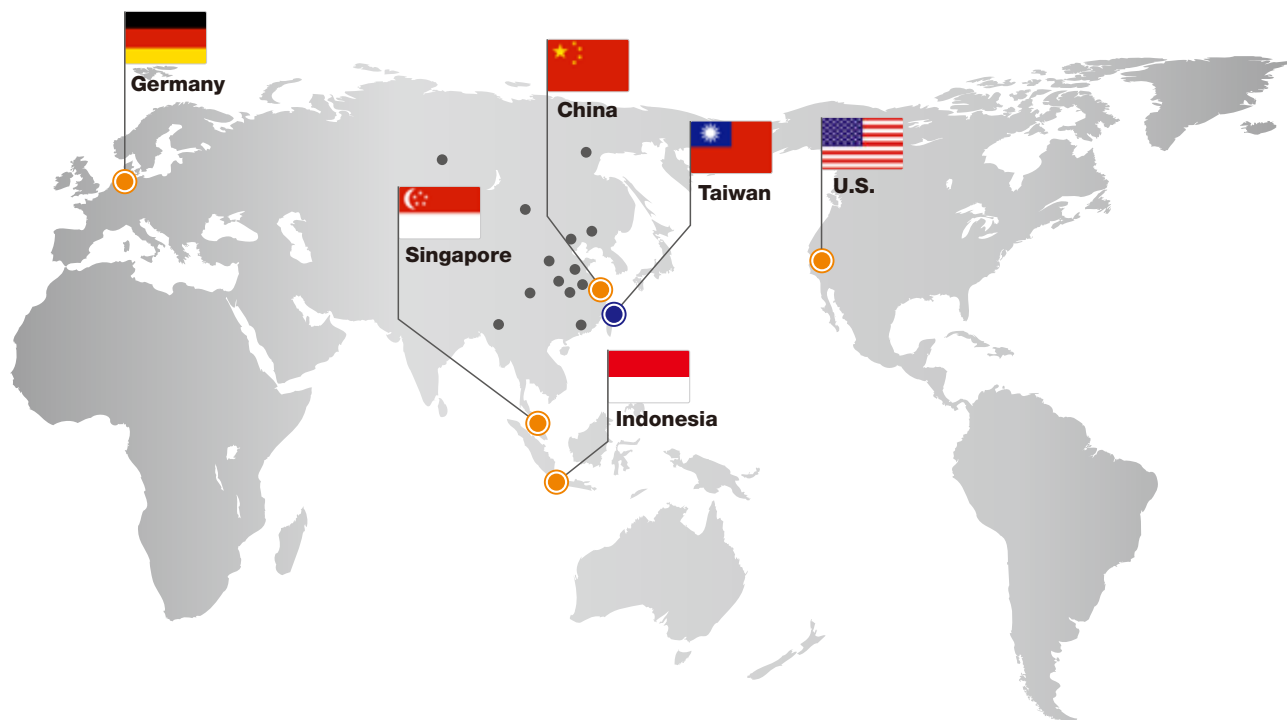

■ Head Quarter

● Taiwan

FineTek Co., Ltd. - Taipei Head Quarter 
No.16, Tzuchiang St., Tucheng Industrial Park
New Taipei City 236, Taiwan
TEL: 886-2-2269-6789
FAX: 886-2-2268-6682
EMAIL: info@fine-tek.com

■ North America

● California, U.S.

Aplus Finetek Sensor Inc. - US Office
355 S. Lemon Ave, Suite D
Walnut, CA 91789
TEL: 1 909 598 2488
FAX: 1 909 598 3188
EMAIL: info@aplusfine.com

■ Europe

● Germany

FineTek GmbH - Germany Office
Bei den Kämpen 26
21220 Seevetal-Ramelsloh, Germany
TEL: +49-(0)4185-8083-12
FAX: +49-(0)4185-8083-80
EMAIL: info@fine-tek.de

■ Asia

● China

Fine automation Co., Ltd. - Shanghai Factory 
No.451 DuHui Rd, MinHang District, Shanghai,
China 201109
TEL: 86-21-6490-7260
EMAIL: info.sh@fine-tek.com

● Singapore

FineTek Pte Ltd. - Singapore Office
37 Kaki Bukit Place, Level 4 Singapore 416215
TEL: 65-6452-6340
EMAIL: info.sg@fine-tek.com

● Indonesia

PT. FineTek Automation Indonesia - Indonesia Office 
PERGUDANGAN TUNAS BITUNG
JL. Raya Serang KM. 13,8, Blok C3 No. 12&15, Bitung Cikupa,
Tangerang 15710
TEL: 62 (021)-2958-1688
EMAIL: info.id@fine-tek.com

● Mütect Instruments GmbH - Germany Office

Bei den Kämpen 26
21220 Seevetal-Ramelsloh, Germany
TEL: +49-(0)4185-8083-0
FAX: +49-(0)4185-8083-80
EMAIL: muetec@muetec.de



Distributor: